



Fire Trak 1 Hr. Shadowline
Standard Wall - 1" Deflection



Fire Trak 2 Hr. Cavity Shadowline
Shaft Wall - 2" Deflection



Fire Trak 2 Hr. Shadowline
Standard Wall - 6" Deflection



LIGHT GAUGE FRAMING
FOR USE IN JOINT SYSTEMS
SEE UL FIRE RESISTANCE DIRECTORY
1N07

U.S. PATENT NO'S 5,471,805 AND 5,755,066

MANUFACTURER

FIRE TRAK CORP., P.O. Box 485, 104 Cedar Ave. S., Watkins, MN 55389
800.394.9875 ph 877.374.1928 fax info@firetrak.com www.firetrak.com

AVAILABILITY

Major Credit Cards are accepted. There is a 24 hour lead time on standard profiles.

DESCRIPTION

The Fire Trak System consists of the Fire Trak ceiling runner with a shoulder offset the thickness of the wall material. A second piece of wall material is fitted tight to the roof or floor deck and then attached to the shoulder. This allows the deck and the Fire Trak ceiling runner to move in relation to the wall studs and allows the overlapping piece of wall material attached to the Fire Trak to slide over the primary wall material.

BENEFITS

Fire Trak is a fire rated Head-of-Wall Joint that has passed current fire and cycle tests at U.L. without fire caulk or spray.

The system is classified and listed for use with U-400 series walls and is good for both roof and floor assemblies.

CODE COMPLIANCE

The Fire Trak System meets all standard building codes and its unique design and exceptional performance are widely recognized and accepted by Building Officials. Fire Trak has U.L. listings for standard walls, cavity walls and shaft walls. It is tested and listed both parallel and perpendicular to the roof and/or floor deck.

TEST STANDARDS:

U.L. 2079 - Tests for Fire Resistance of Building Joint Systems

ASTM E1966 - Standard Test Method for Fire Resistive Joint Systems

CYCLING REQUIREMENTS:

The test assemblies were cycled 500 times, 100 cycles at 30 CPM and 400 cycles at 10 CPM.

The system has Class I, II and III cycling capabilities.

MOVEMENT CAPABILITIES

The Fire Trak System does not require fire caulk or spray to achieve a fire rating. This allows the Fire Trak System substantially greater movement capabilities than other systems. The Fire Trak System achieves a full 100% compression and/or extension and has been tested and listed with U.L. for deflection up to 6".

FIRE RATED CONDITION:

Up to 3" of Compression and 3" of Extension

Up to 6" of Compression or Extension

PATENTED SYSTEM

U.S. Patent No.'s 5,471,805 and 5,755,066 cover the Fire Trak System. Creating a shoulder on a track to attach an overlapping board for the purpose of joint movement is part of Fire Trak's patented assembly and its use constitutes patent infringement.

U.L. LISTINGS

	<u>1" Compression and 1" Extension (2" Range of Motion)*</u>		% Compression (Deflection) Movement	Actual Compression (Deflection) by "
HW-D-0060	Standard wall Perpendicular and parallel against steel and concrete decks	1 to 3 hour	100%	1"
HW-D-0061	Cavity wall Perpendicular and parallel against steel and concrete decks	1 to 3 hour	100%	1"
HW-D-0117	Standard & Cavity walls Perpendicular to metal decks with flute filled with cementitious fireproofing	1 and 2 hour	100%	1"
HW-D-0118	Standard & Cavity walls Perpendicular to metal decks with flute filled with fire caulk or fire spray	1 and 2 hour	100%	1"
HW-D-0119	Shaft wall Perpendicular and parallel against steel and concrete decks	1 to 3 hour	100%	1"
HW-D-0120	Shaft wall Perpendicular and parallel against steel and concrete decks	1 to 3 hour	100%	1"
HW-D-0400	Shaft wall Parallel under steel beam	1 and 2 hour	100%	1"
	<u>3" compression and 3" extension (6" range of motion)*</u>			
HW-D-1011	Standard wall Perpendicular and parallel against steel and concrete decks	1 to 3 hour	100%	3"
HW-D-1012	Cavity wall Perpendicular and parallel against steel and concrete decks	1 to 3 hour	100%	3"
HW-D-1019	Standard & Cavity walls Perpendicular to metal decks with flute filled with cementitious fireproofing	1 and 2 hour	100%	3"
HW-D-1020	Standard & Cavity walls Perpendicular to metal decks with flute filled with fire caulk or fire spray	1 and 2 hour	100%	3"

*** Tracks can be configured to any deflection between 1" and 6".**

HEAD-OF-WALL DETAIL

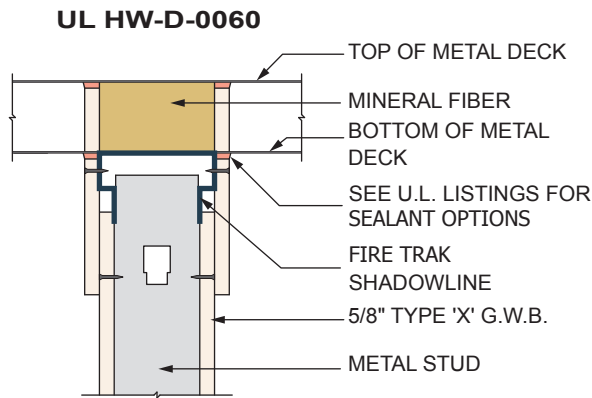

Perpendicular to Metal Deck
1 Hr. Rating - 1" Deflection

STEEL SPECIFICATIONS

- 20 GAUGE** (.0356 min thickness) galvanized steel
Conforms to ASTM C-645
Steel Conforms to ASTM A-653, Minimum 33,000 ksi yield strength
Galvanized in accordance with ASTM A-924, G-60
- 18 GAUGE** (.0466 min thickness) galvanized steel
Conforms to ASTM C-645
Steel Conforms to ASTM A-653, Minimum 33,000 ksi yield strength
Galvanized in accordance with ASTM A-924, G-60
- 16 GAUGE** (.0575 min thickness) galvanized steel
Conforms to ASTM C-645
Steel Conforms to ASTM A-653, Minimum 50,000 ksi yield strength
Galvanized in accordance with ASTM A-924, G-60
- 14 GAUGE** (.070 min thickness) galvanized steel
Conforms to ASTM C-645
Steel Conforms to ASTM A-653, Minimum 50,000 ksi yield strength
Galvanized in accordance with ASTM A-924, G-60
- 12 GAUGE** (.099 min thickness) galvanized steel
Conforms to ASTM C-645
Steel Conforms to ASTM A-653, Minimum 50,000 ksi yield strength
Galvanized in accordance with ASTM A-924, G-60
- 10 GAUGE** (1.29 min thickness) galvanized steel
Conforms to ASTM C-645
Steel Conforms to ASTM A-653, Minimum 50,000 ksi yield strength
Galvanized in accordance with ASTM A-924, G-60

SUBMITTAL APPROVALS

Job Name: _____
 Contractor: _____
 Approved By: _____
 Date: _____